

SCHNITT B-B

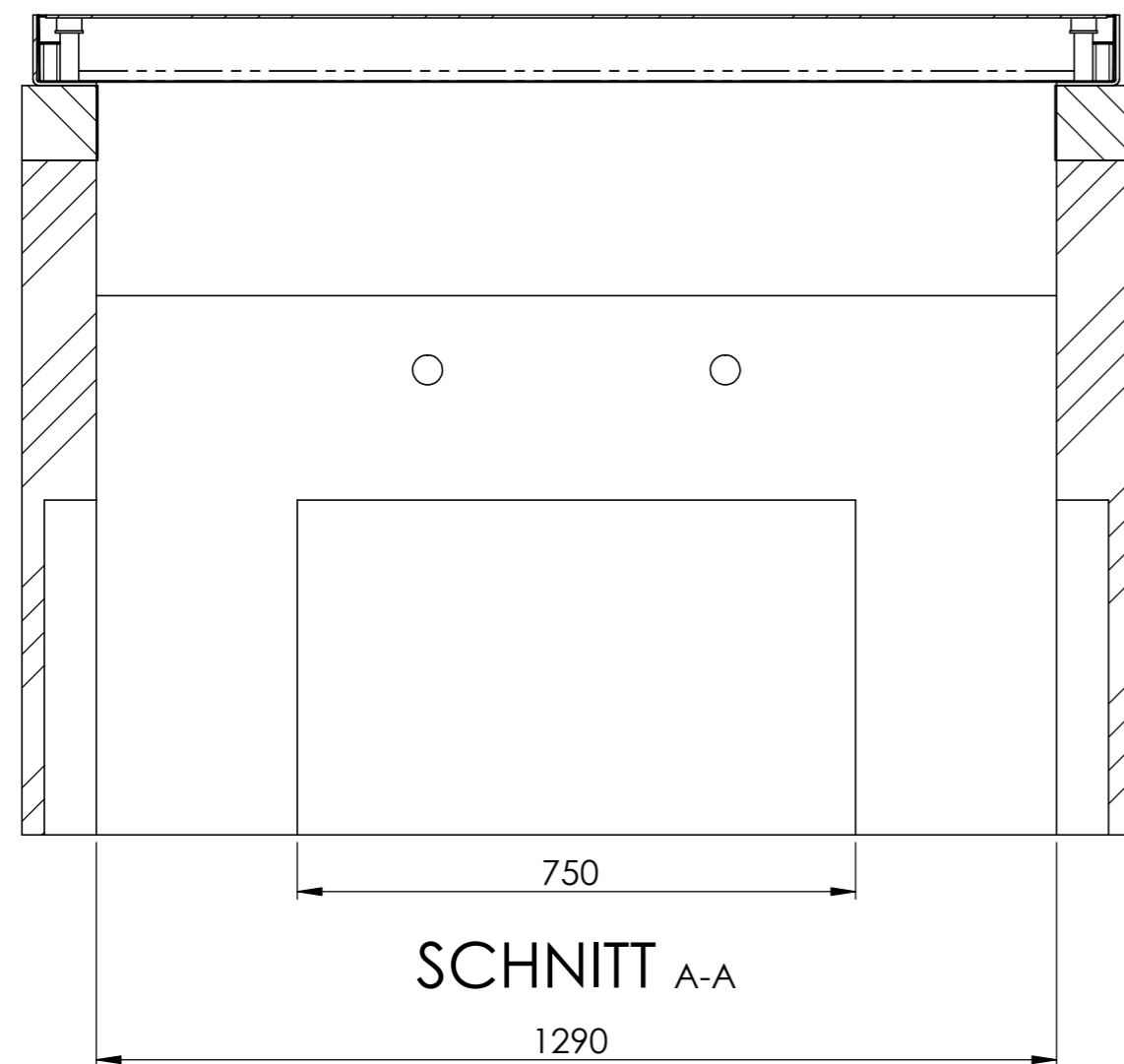

SCHNITT A-A

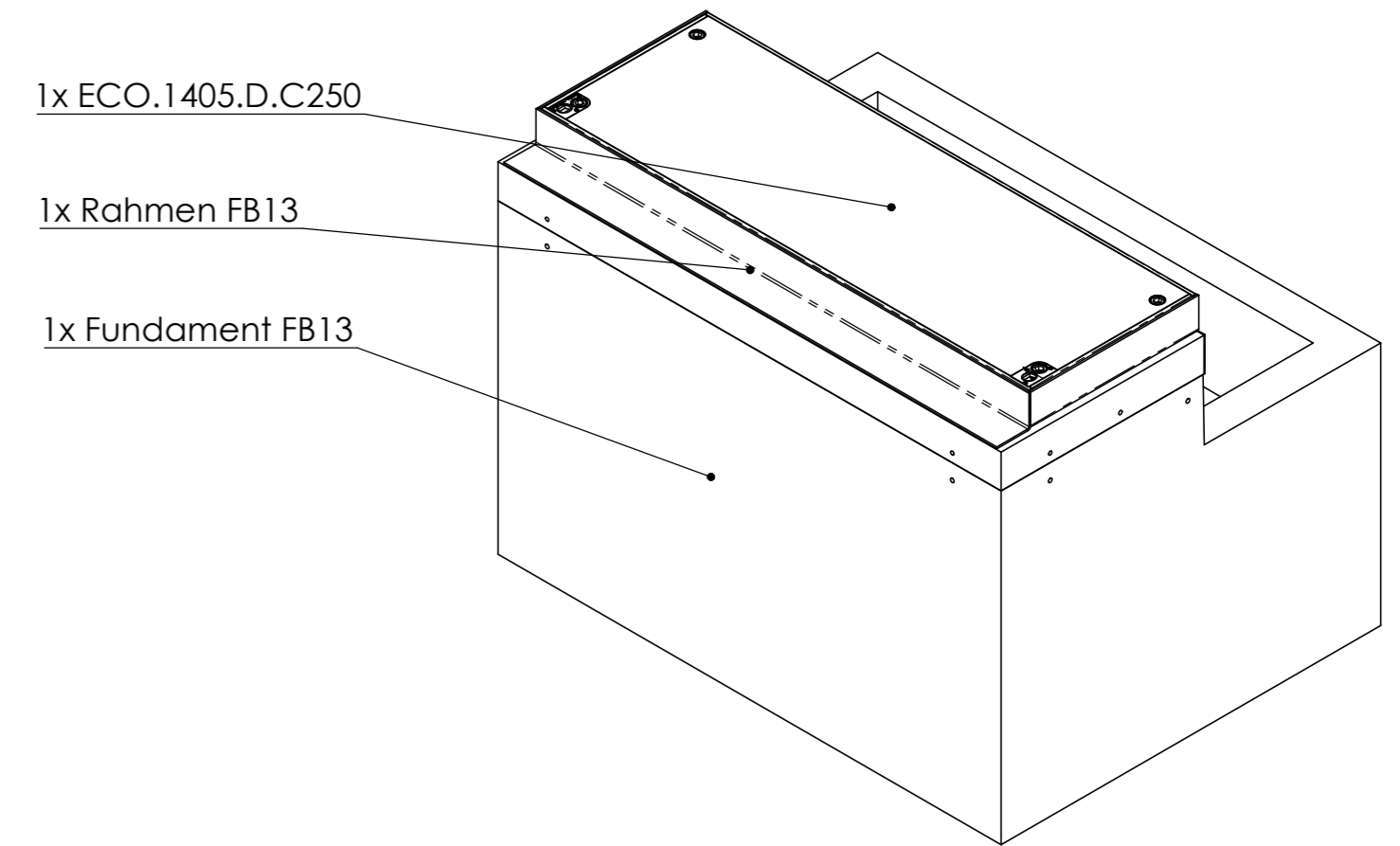

Allgemeintoleranzen ISO 2768-m		Material:		Gewicht:		
				860 kg		
FB13 + Florida 13 Ohne Kabine C250			Massstab 1:5	Gezeichnet	21.03.2022	MH
				Geprüft	21.03.2022	MH
				Datum	Name	
			Format A2	Zeichnungsnr. 020-670		